

GMR Disc Brake Caliper

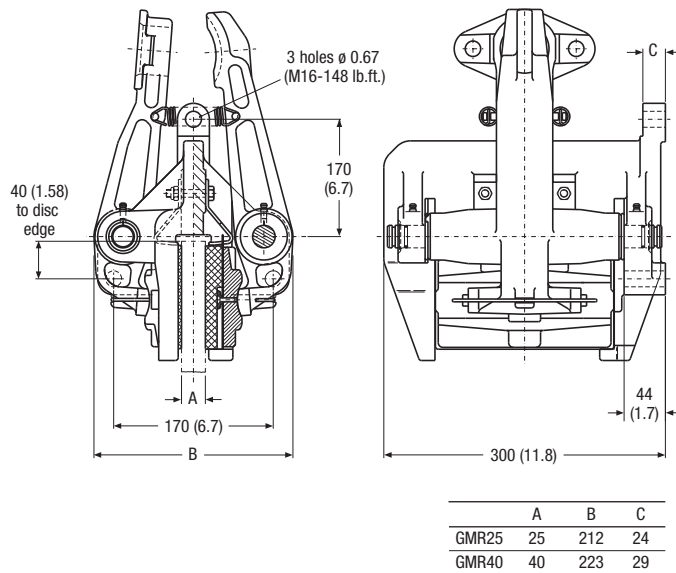

The Twiflex GMR and GMR40 series of disc brake calipers is suitable for use with discs of 25.4mm, and 40mm thick respectively. Minimum disc diameter is 610mm.

Normally one or two calipers are used per disc, but the number may be increased depending on disc size. The brakes may be positioned at any angle around the periphery of the disc, but should ideally be mounted horizontally (i.e. at the 3 o'clock or 9 o'clock position). If the caliper mounting angle is greater than 10° from the horizontal, or on vertical shaft applications, it should be fitted with an inclined mounting kit. A range of brake discs is available from Twiflex (see Disc and Hub Assemblies).

For pneumatic operation use dry, filtered and non-lubricated compressed air. Pneumatic brakes require a control valve, operated either manually or by pneumatic or electrical signal.

The ratings shown on the graphs are based on fully bedded in and conditioned brake pads with a nominal friction coefficient $\mu = 0.4$. Twiflex disc brakes must be used with Twiflex asbestos free brake pads.

Effective disc radius = actual radius (m) - 0.06m.

GMRP Pneumatically Applied – Spring Released

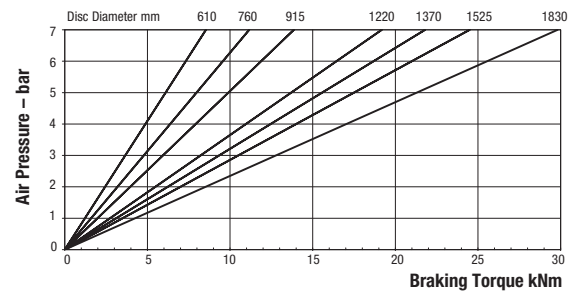
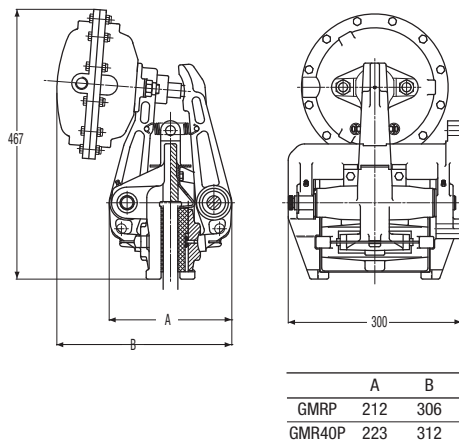

Maximum Pressure 7 bar
 Maximum Braking Force = 36kN @ 7 bar
 Weight of caliper and thruster - 40.8kg
 Weight of thruster only - 6.8kg
 Volume displacement of thruster at full stroke = 1.8 l

GMRH Hydraulically Applied – Spring Released

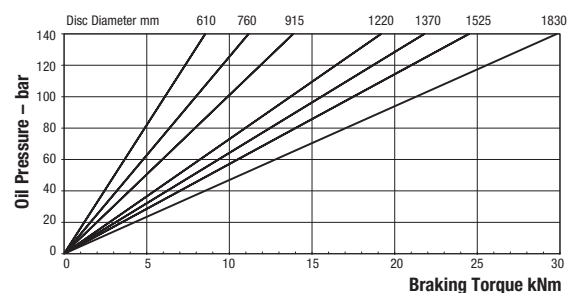
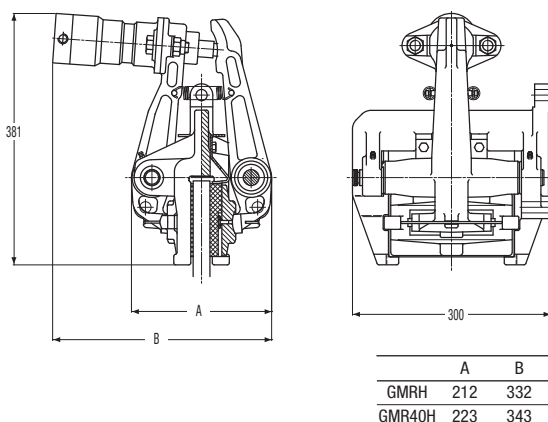

Maximum Pressure 140 bar
 Maximum Braking Force = 36kN @ 140 bar
 Weight of caliper and thruster - 36.9kg
 Weight of thruster only - 2.9kg
 Volume displacement of thruster at full stroke = 40ml

Retraction pressures where shown are calculated and may vary depending on spring tolerance.

GMR Series

GMRS Spring Applied – Pneumatically Released

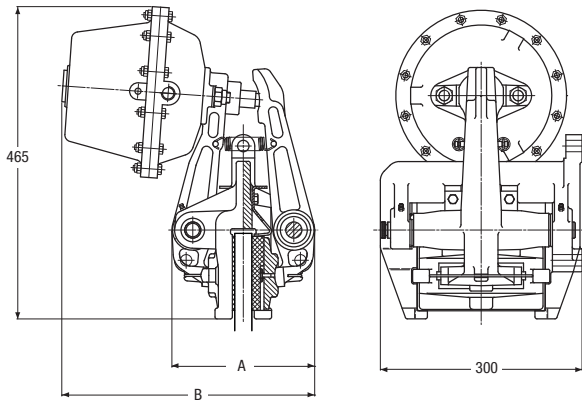

	A	B
GMRS	212	376
GMR40S	223	382

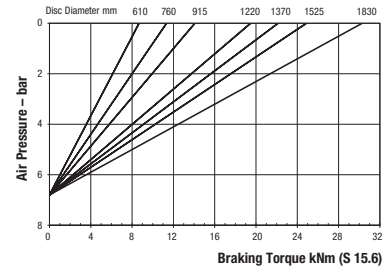

Maximum Braking Force S 15.6: 36kN
 Minimum Pressure for full retraction: 8.4 bar
 Weight of caliper and thruster - 49kg
 Weight of thruster only - 15kg
 Volume displacement of thruster at full retraction = 1.3 l

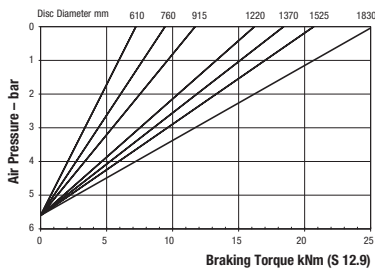

Maximum Braking Force S 12.9: 30kN
 Minimum Pressure for full retraction: 7 bar
 Weight of caliper and thruster - 48kg
 Weight of thruster only - 14kg
 Volume displacement of thruster at full retraction = 1.3 l

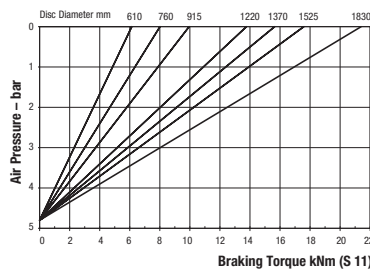

Maximum Braking Force S 11: 25kN
 Minimum Pressure for full retraction: 6 bar
 Weight of caliper and thruster - 47.2kg
 Weight of thruster only - 13.2kg
 Volume displacement of thruster at full retraction = 1.3 l

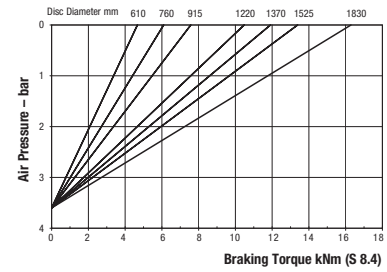

Maximum Braking Force S 8.4: 19.5kN
 Minimum Pressure for full retraction: 4.8 bar
 Weight of caliper and thruster - 46.2kg
 Weight of thruster only - 12.2kg
 Volume displacement of thruster at full retraction = 1.3 l

GMRSD Spring Applied – Pneumatically Released

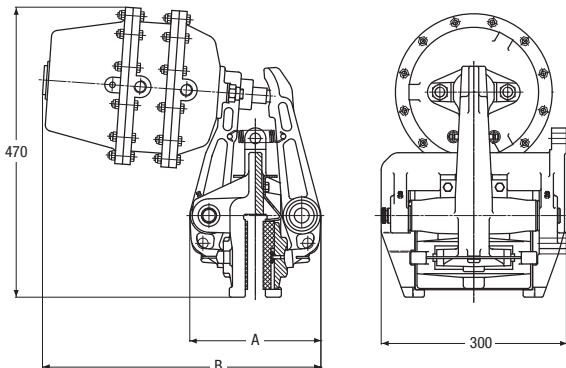

	A	B
GMRSD	212	451
GMR40SD	223	457

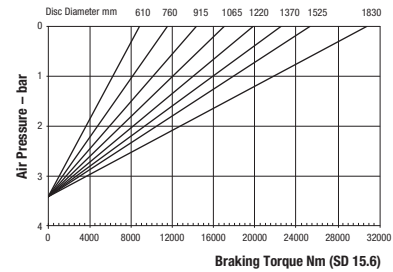

Maximum Braking Force SD 15.6: 36kN
 Minimum Pressure for full retraction: 4.6 bar
 Weight of caliper and thruster - 55kg
 Weight of thruster only - 21kg
 Volume displacement of thruster at full retraction = 2.5 l

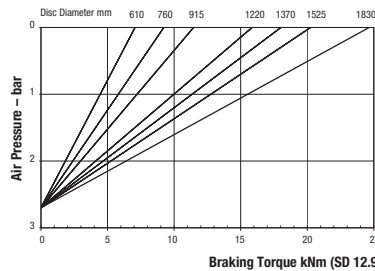

Maximum Braking Force SD 12.9: 30kN
 Minimum Pressure for full retraction: 3.8 bar
 Weight of caliper and thruster - 54kg
 Weight of thruster only - 20kg
 Volume displacement of thruster at full retraction = 2.5 l

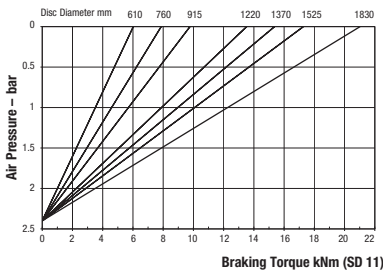

Maximum Braking Force SD 11: 25kN
 Minimum Pressure for full retraction: 3.3 bar
 Weight of caliper and thruster - 53.2kg
 Weight of thruster only - 19.2kg
 Volume displacement of thruster at full retraction = 2.5 l

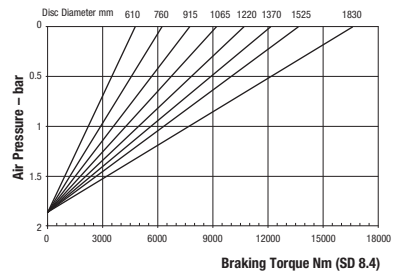

Maximum Braking Force SD 8.4: 19.5kN
 Minimum Pressure for full retraction: 2.4 bar
 Weight of caliper and thruster - 52.2kg
 Weight of thruster only - 18.2kg
 Volume displacement of thruster at full retraction = 2.5 l

Retraction pressures where shown are calculated and may vary depending on spring tolerance.

GMRSH Spring Applied – Hydraulically Released

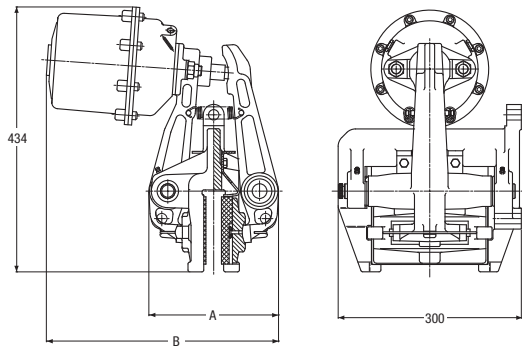

	A	B
GMRSH	212	380
GMR40SH	223	387

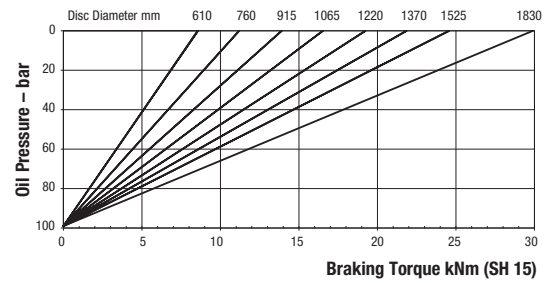

Maximum Braking Force SH 15: 35kN
 Minimum Pressure for full retraction: 120 bar
 Weight of caliper and thruster - 53kg
 Weight of thruster only - 19kg
 Volume displacement of thruster at full retraction = 56ml

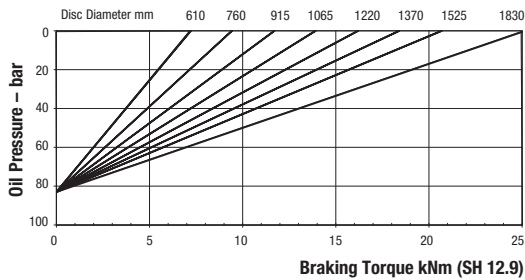

Maximum Braking Force SH 12.9: 30kN
 Minimum Pressure for full retraction: 100 bar
 Weight of caliper and thruster - 52kg
 Weight of thruster only - 18kg
 Volume displacement of thruster at full retraction = 56ml

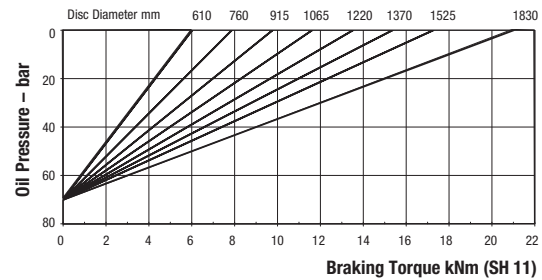

Maximum Braking Force SH 11: 25kN
 Minimum Pressure for full retraction: 92 bar
 Weight of caliper and thruster - 51.2kg
 Weight of thruster only - 17.2kg
 Volume displacement of thruster at full retraction = 56ml

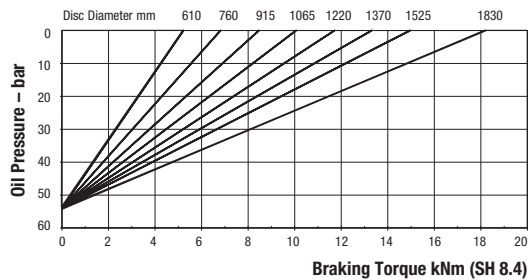

Maximum Braking Force SH 8.4: 19.5kN
 Minimum Pressure for full retraction: 65 bar
 Weight of caliper and thruster - 50.2kg
 Weight of thruster only - 16.2kg
 Volume displacement of thruster at full retraction = 56ml

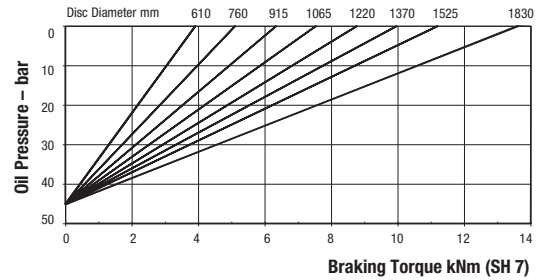

Maximum Braking Force SH 7: 16.5kN
 Minimum Pressure for full retraction: 59 bar
 Weight of caliper and thruster - 49.7kg
 Weight of thruster only - 15.7kg
 Volume displacement of thruster at full retraction = 56ml

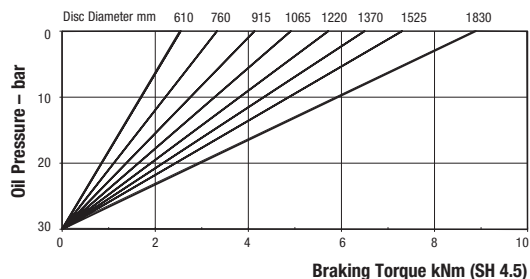

Maximum Braking Force SH 4.5: 10.5kN
 Minimum Pressure for full retraction: 38 bar
 Weight of caliper and thruster - 48.7kg
 Weight of thruster only - 14.7kg
 Volume displacement of thruster at full retraction = 56ml

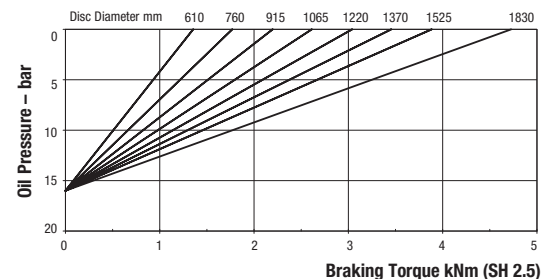

Maximum Braking Force SH 2.5: 6kN
 Minimum Pressure for full retraction: 21 bar
 Weight of caliper and thruster - 47.9kg
 Weight of thruster only - 13.9kg
 Volume displacement of thruster at full retraction = 56ml

Retraction pressures where shown are calculated and may vary depending on spring tolerance.